



LUMS^X

MACHINE LEARNING

Dr. Agha Ali Raza

LUMSx is the center for online learning and professional development at LUMS. We extend LUMS' excellence in teaching and research beyond its borders by leveraging technology and innovative pedagogy. Our courses aim to bridge critical knowledge & skill gaps for Pakistani learners and to meet their diverse learning needs, we offer **Massive Open Online Courses (MOOCs)**, **Hybrid Courses**, **Synchronous (Live) Courses**, and **Free Open Online Courses (OpenCourseWare)**. We intend to harness technology for enhancing access, improving educational quality, and amplifying education's impact.

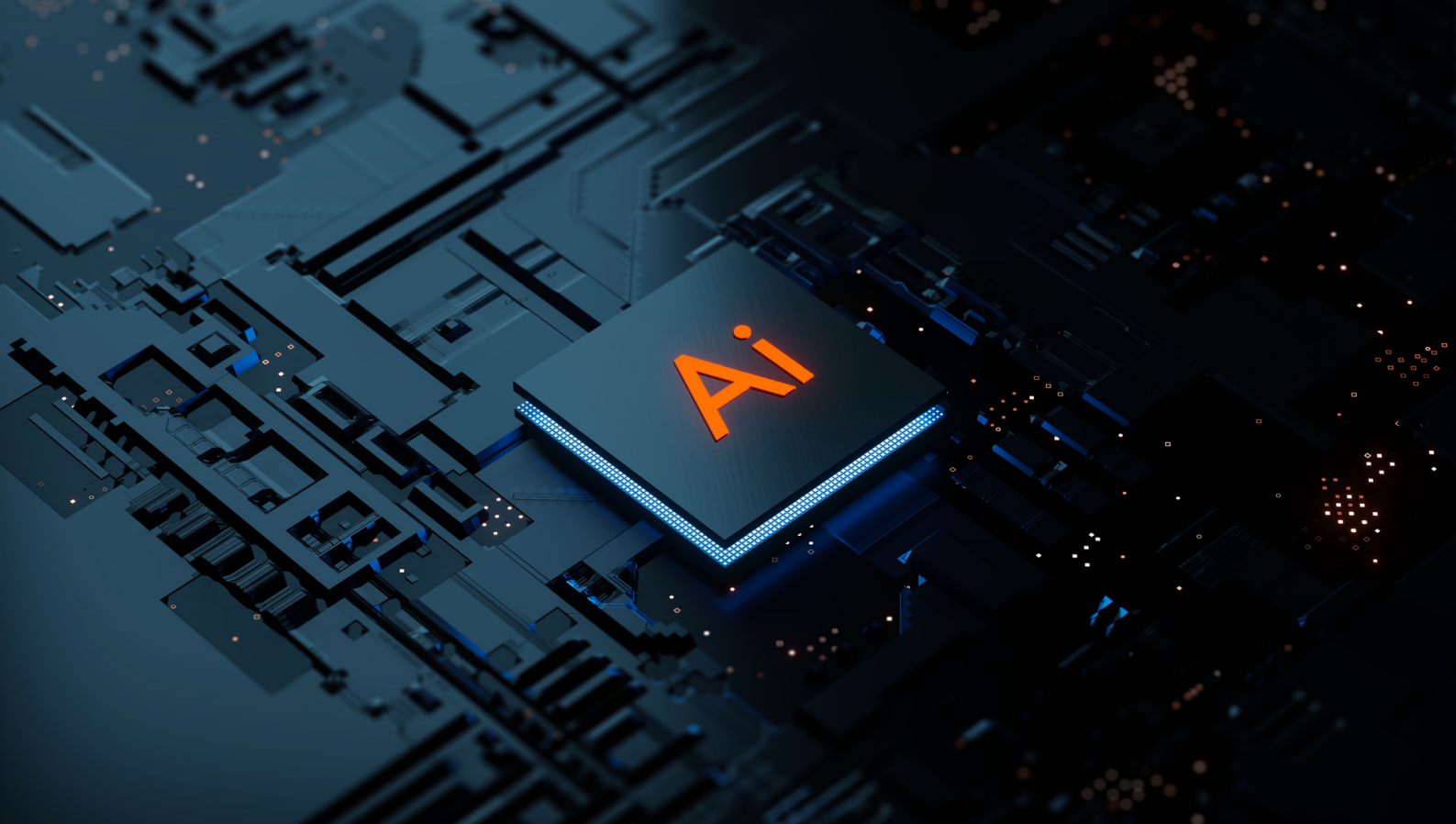

Course Format: Self-Paced

Language: English, Urdu

Starting Date: Available Now

Duration: 3 months

Price: PKR. 15,000

Early Bird Discount: **PKR. 11,250**

ABOUT THIS COURSE



Are you intrigued by the world of Artificial Intelligence (AI) and wish to learn about the fascinating field of Machine Learning (ML)? With applications ranging from self-driving cars to voice assistants and large language models, Machine Learning is revolutionizing the way we interact with the world at a fast-evolving pace.

This course is designed to equip you with the essential skills, concepts, and applications of machine learning, setting you on the path to becoming proficient in this field. In this structured and immersive course, you'll go through fundamental concepts to advanced techniques, guided by a logical progression through eleven well-curated modules. Whether you are diving into the nuances of supervised learning, grasping the principles behind neural networks, or exploring the ethical dilemmas encompassing AI and ML, this course provides a comprehensive learning experience.

With captivating videos, hands-on exercises, and peer and staff feedback, you will be able to apply machine learning concepts to real-world scenarios. By the end of this course, you'll not only have a deep understanding of machine learning techniques but also know how to leverage them responsibly and ethically in various fields.

This course is led by Dr. Agha Ali Raza, known for his stimulating teaching style and ability to deconstruct some of the most complex ML algorithms into everyday, applicable concepts. Let's embark on this enriching learning journey together, paving your way to becoming a proficient machine learning practitioner!

WHAT WILL YOU LEARN

Course Objective: Ignite enthusiasm for Machine Learning and equip learners with the foundational skills to harness its potential.

By the end of this machine learning course, learners will be able to:

- Intuitively grasp the core principles behind Machine Learning models, tools, and methodologies.
- Master the mathematical underpinnings of statistical learning.
- Rigorously navigate the lifecycle of designing, executing, and assessing key Machine Learning models.
- Select the optimal algorithm for specific challenges and discern the merits and limitations of each.
- Comprehend the holistic integration of ML in application areas, spanning data sourcing, annotation, algorithm selection, societal biases, model explainability, and its transformative implications.

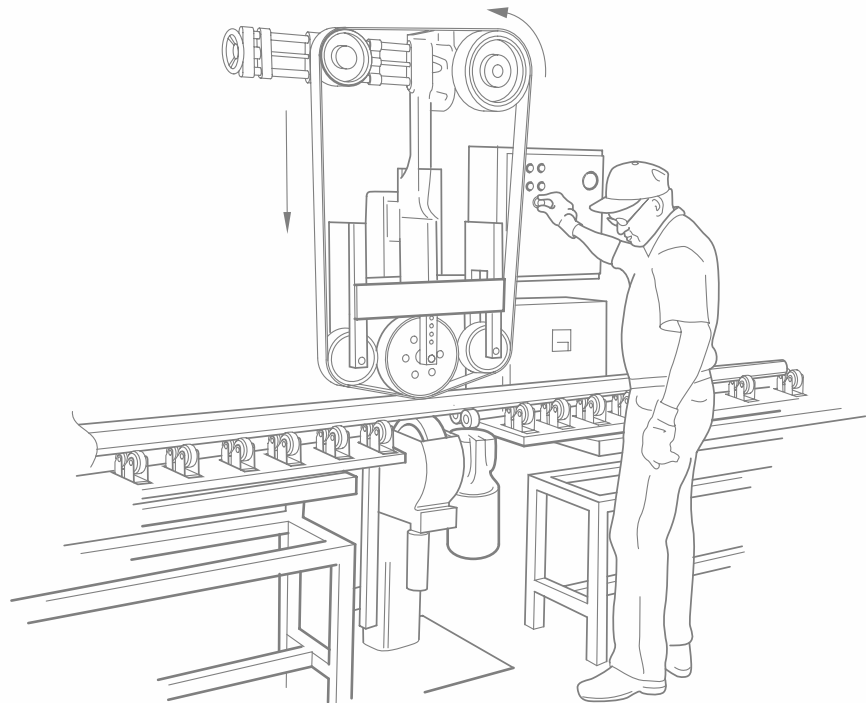

MEET YOUR INSTRUCTOR



Course Instructor

DR. AGHA ALI RAZA

*Assistant Professor,
Syed Babar Ali School of
Science & Engineering,
LUMS*

Dr. Agha Ali Raza is an Assistant Professor in the Department of Computer Science at LUMS and the founding director of the Center for Speech and Language Technologies (CSaLT). He is a Fulbright Scholar and received his Ph.D. from the Language Technologies Institute, School of Computer Science at Carnegie Mellon University, Pittsburgh, USA.

His research interests include Speech & Natural Language Processing, Speech-based Human Computer Interfaces, and Information & Communication Technologies for Development (ICT4D). The aim of his research is to enable information access and social connectivity for under-connected and under-served populations (low-literate, low-income, tech naive, visually impaired, linguistically/socially marginalized, and geographically remote communities, and oral cultures) throughout the developing world. His work in Speech and Language technologies is focused on the localization of linguistic resources and techniques to Pakistani context for the development of Speech Recognition, Text-to-Speech, Voice-biometrics, Spoken Term Detection and relevant capabilities. I teach Natural Language Processing, Speech Processing and Machine Learning at graduate and undergraduate levels.

Dr. Raza's research has been funded by prestigious organizations like Google Inc., Facebook Research, UNICEF, GIZ, National Institutes of Health (NIH), the National Academies of Sciences, Engineering, Medicine, Keck Futures Initiative (NAKFI), and the Higher Education Commission of Pakistan. He is also an Associate Chair in the program committee for CHI.

COURSE OUTLINE

MODULE

LEARNING OUTCOMES

Welcome to Machine Learning	Welcome to the course on Machine Learning! In this module you will learn about what Machine Learning is? Who is this course for? What this course contains and how will you be able to benefit from this course. This introductory module will give you information on the instructor's profile, course syllabus and objectives, different features of the course, grading policies, expectations around academic honesty, frequently asked questions, and a chance to chat with your peers.
Introduction to Machine Learning	This module will uncover the wonderful world of machine learning, demonstrating its ubiquity in our lives and explaining its underlying concepts. Through a mix of theory and examples, this module will give you a comprehensive understanding of machine learning's key concepts, historical background, applications, challenges and how it can be harnessed for social good. The module will also give you an opportunity to learn the basics of python and apply them through a programming assessment.
Supervised Learning	Supervised learning is one of the fundamental techniques in Machine Learning. This module will equip you with the foundational knowledge and practical skills necessary to apply supervised learning algorithms to real-world problems. Through a combination of theoretical concepts and hands-on exercises, you will gain a solid understanding of the principles, algorithms, and evaluation methods involved in supervised learning.
KNN	K-NN is a non-parametric method used for both classification and regression tasks. This module will familiarize you with the underlying principles, implementation, and evaluation of the K-NN algorithm. Through theoretical explanations and practical examples, you will gain proficiency in applying K-NN to real-world problems, selecting an appropriate value for K, handling distance metrics, dealing with imbalanced data, and optimizing model performance.

MODULE

LEARNING OUTCOMES

Evaluation of Classifiers

The module provides a comprehensive understanding of essential evaluation metrics for classification tasks. You will begin with learning about accuracy, build up to precision, recall, and F1-score, which are widely used performance measures that assess the effectiveness of classifiers in predicting class labels. This module will equip you with the knowledge and skills to calculate and interpret these metrics accurately. You will gain a solid understanding of the concepts behind precision (the proportion of correctly predicted positive instances), recall (the proportion of actual positive instances correctly predicted), and F1-score (a harmonic mean of precision and recall). Through practical examples and exercises, you will learn how to apply these metrics to assess classifier performance and make informed decisions based on their results.

Linear Regression

In this module, you will gain a comprehensive understanding of linear regression, a widely-used technique in predictive modeling. You will learn the fundamental principles and assumptions of linear regression, including linearity and independence. The module will also focus on parameter estimation, coefficient interpretation, and prediction. Additionally, important topics like regularization techniques will be explored. Through hands-on exercises and real-world datasets, you will develop practical skills in building, evaluating, and improving linear regression models, enabling you to analyze data, make accurate predictions, and extract valuable insights.

Logistic Regression

Logistic regression is a powerful tool used to predict the probability of a binary outcome based on a set of input variables. In this module you will cover the underlying concepts and assumptions of logistic regression, including the logistic function and loss function. You will also explore the process of model fitting, parameter estimation, and interpretation of results. Practical examples and hands-on exercises are included to enhance your understanding and application of logistic regression in real-world scenarios. By the end of the module, you will have a solid foundation in logistic regression and you will be equipped to utilize this technique for predictive modeling and decision-making tasks.

Neural Networks

The module on Neural Networks provides you with an introduction to this powerful machine learning technique that mimics the structure and functioning of the human brain. Neural networks are composed of interconnected nodes, or artificial neurons, organized in layers that process and transform data. Here you will cover the fundamental concepts and components of neural networks, including activation functions, weight initialization, forward and backward propagation, and gradient descent optimization.

MODULE

LEARNING OUTCOMES

Support Vector Machines	<p>The module on Support Vector Machines (SVM) offers an introduction to this powerful supervised learning algorithm used for classification and regression tasks. SVMs aim to find the optimal hyperplane that separates data points of different classes with the largest margin. In this module you will learn about the underlying principles of SVM, including the concept of support vectors, kernel functions, and the margin optimization objective. You will explore both linear and nonlinear SVMs, highlighting their strengths and limitations.</p>
Bayes Theorem	<p>This module provides you with an introduction to Bayes Theorem, a fundamental concept in probability theory and statistics. Bayes Theorem allows us to update our beliefs about the probability of an event based on new evidence or information. The content sheds light on the core components of Bayes Theorem, including prior probabilities, likelihoods, and posterior probabilities. It also explores how Bayes Theorem can be applied to various scenarios, such as medical diagnostics and spam filtering.</p>
Naive Bayes Classifier	<p>This module introduces the Naive Bayes classifier, a simple yet effective probabilistic algorithm used for classification tasks. The Naive Bayes classifier is based on Bayes' theorem and makes the assumption of independence among features. Here, you will cover the key concepts and workings of the Naive Bayes classifier, including the calculation of prior probabilities, likelihoods, and posterior probabilities.</p>
Responsible AI and Machine Learning for Development	<p>This module aims to unveil the 'black box' nature of artificial intelligence and machine learning models, enabling deeper understanding of their inner workings and addressing the multifaceted issues related to AI ethics, fairness and explainability. It covers fairness in AI, interpretability of ML models, sources of bias and techniques to mitigate bias. The module also touches upon ethics in AI to understand the moral principles guiding AI development and its use. Lastly, the content covers machine learning for development, explaining how ML techniques can be used to address social and economic challenges in developing countries.</p>



MACHINE LEARNING

[ENROLL NOW](#)

As an *online learning gateway* of LUMS, we aim to extend LUMS' excellence in teaching and research *beyond its borders* by leveraging technology.